

Commissioning Instructions
SAS 3...11
SAS 11PUST, 22PUST

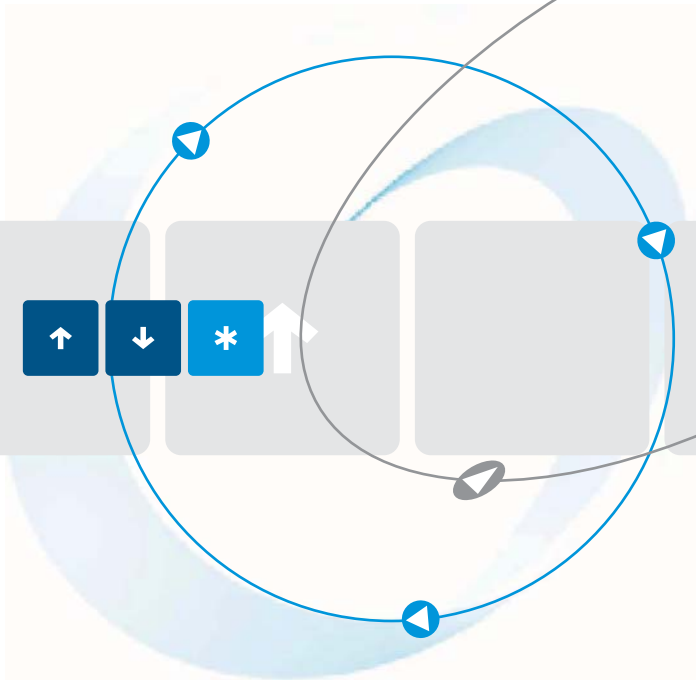

as per: 05/09 10800.10002

Table of Contents	Page
1. Safety notes	3
2. Declaration of conformity	3
3. Functional principle	4
4. Technical data	4
5. Installation	4
6. Connection	5
7. LED Indicators	5
8. Parameter adjustments	5
9. Commissioning	6
10. Installation guidelines	6
10.1 Connection diagram	6
10.2 Typical connections	7

These commissioning instructions were made with great care. Nevertheless, the PETER electronic GmbH & Co. KG does not assume liability for damage resulting from mistakes possibly contained in this manual. Technical changes that serve to improve the product are subject to change without notice.

1. Safety notes

The described devices are electrical equipment for the application in industrial electrical power installations. An impermissible removal of the covers during operation can cause serious damage to your health, since these devices contain live parts with high voltages.

Adjustment work may only be performed by trained staff observing the safety regulations. Assembly and mounting work may only be carried out with the equipment de-energized.

Make sure that all the drive components are properly earthed.

Read these commissioning instructions carefully before putting the soft starter into operation.

Besides, the user must ensure that the devices and associated components are fitted and connected in accordance with the applicable local, legal and technical regulations. The VDE-regulations VDE 0100, VDE 0110, VDE 0160 and VDE 0113, plus the appropriate regulations of the TÜV (Technical Inspectorate) and the employers' liability insurance associations apply in Germany.

The user must make sure that the drive assumes a safe operating state following a device failure, in the event of maloperation, or if the control unit has failed etc..

The control terminals X1,X2,X3 and X4 lead mains potential.

Even if the motor is at rest, it is **not** physically separated from the mains.

2. Declaration of conformity

In industrial linguistic usage the drive controllers of the type SAS are called "devices", however, in the sense of the "device-safety-law", the "EMC-law" or the "EC-guideline for machinery" they are not devices or machines ready for use or connection but they are components. It is only possible to define their final function, when these components are integrated into the design and construction of the user.

To be able to use the devices to their intended purpose, it requires power supply networks according to DIN EN 50160 (IEC38) .

The user takes the responsibility to ensure that the user's design and construction comply with the applicable legal provisions.

The commissioning is strictly forbidden as long as the conformity of the final product with the guideline 2006/42/EC (machinery guideline) is not proved.

The devices of the SAS-series are electrical equipment that is used in industrial electrical power installations. They are designed for the application in machines, in order to reduce the starting torque of drives with three-phase motors. With due regard to the installation guidelines they meet the following requirements:

Emitted interference:	Continuous duty	EN 50081-1
	Ramp-up	EN 60947-4-2, IEC 947-4-2
Immunity to interference:	EN 50082-2	1995

CE

Dr. Thomas Stiller
Managing Director



3. Functional principle

By means of a power semiconductor whose trigger angle is time-dependently controlled, one of the three motor phases is influenced to the effect that first a small (adjustable) and then a continuously increasing current flows when the device is switched on. The soft starter converts the normally circular rotating field in the motor into an elliptical field which during the acceleration period builds itself up to become circular again. During this period of time the motor torque increases from zero - or from an adjustable value - up to the required maximum torque. The maximum starting torque is reached at the end of the ramp-up time. This enables safe acceleration even in drives with high breakaway torques. After the acceleration period the electronics is bypassed by an integrated relay contact, so that the motor is again directly supplied from the mains.

4. Technical data

Type designation	SAS				SAS .. PUST	
	3	5,5	7,5	11	11	22
Mains/Motor voltage X1-X2 jumpered according to DIN EN 50160 (IEC 38)	160 ... 240V ± 10%				400V ± 15%	
Mains/Motor voltage X1-X2 not jumpered according to DIN EN 50160 (IEC 38)	380 ... 480V ± 10%					
Mains frequency	50/60Hz				50Hz	
Motor rating at 230V in kW	1,5	3	4	5,5		
Motor rating at 400V in kW	3	5,5	7,5	11	11	22
min. Motor load	10% of the device power rating					
Starting torque	0 bis 50%					
Starting time	0,5 bis 5s					
Repeatability	200ms					
max. Switching cycle per hour	100	80	50	30	120	60
Power draw of the electronics in VA	3,5	3,5	3,5	3,5	10	10
Operating / storage temperature	0°C ... 45°C / -25°C ... 75°C					
Environment	Overvoltage category III pollution degree 2					
Dimensions in mm	Height	122	120	120	172	172
	Width	45	45	100	100	175
	Depth	73	73	73	73	200
Gewicht in g	300	300	500	500	2700	3000

The PUST-version is suitable for all winding connections, even for Dahlander pole-changing motors and motors with separated windings.

5. Installation

Up to the type SAS 11 the electronics is accommodated in a housing (IP20). This housing is suitable for being snap-mounted onto 35mm standard rails or for being fixed with screws. The soft starters SAS 11 PUST and 22 PUST are to be fitted with the terminal strip facing downwards.

6. Connection

Only connect the device according to the attached connection diagram.

(..) = SAS 11PUST and SAS 22PUST

Terminal 1L1 (L1)	via main or reversing contactor to L1 mains cable
Terminal 3L2 (L2)	via main or reversing contactor to L2 mains cable
Terminal 5L3 (L3)	via main or reversing contactor to L3 mains cable
Terminal 2T1 (U)	to motor terminal U
Terminal 4T2 (V)	to motor terminal V
Terminal 6T3 (W)	to motor terminal W
Terminal X1,X2	X1,X2 not jumpered 380 ... 480V/AC \pm 10%
	X1,X2 jumpered 160 ... 240V/AC \pm 10%
Terminal X3,X4	In the case of pole-changing motors with potential-free make-contacts of the pole-changing contactors connect acc. to terminal diagram. In the case of all other motors these terminals are to be jumpered.

The usual measures for line and motor protection are to be taken. In the case of frequent operation it is recommended - as a motor protective measure - to monitor the winding temperature, since the thermal stress increases and the permissible switching rate of the motor decreases.

Attention: The motors must not be operated in de-coupled condition without load.
In this case their soft start behaviour is not very distinct.

7. LED Indicators

When the green LED is illuminated the soft starter is ready for operation.

The yellow LED is illuminated when the acceleration period is over.

8. Parameter adjustments

Adjusting the ramp-up time

With the trimmer "t" the time until the Triac is bypassed by the integrated relay can be infinitely adjusted from 0.5 to 5 seconds.

Adjusting the starting torque

With the trimmer "M" the starting torque can be infinitely adjusted from 0 to 50% of the maximum value.

9. Commissioning

Adjust trimmer "M" to left stop (minimum adjustment) and trimmer "t" to right stop (maximum adjustment).

Switch on the motor and turn trimmer "M" clockwise until the motor, when being switched on, starts up immediately. Unnecessary humming of the motor is to be avoided (temperature rise). The adjustment is to be checked by switching the soft starter several times off and on.

In order to reduce additional thermal stress, the ramp-up time is to be selected as short as possible by turning the trimmer "t" counter-clockwise.

Attention



If the ramp-up time is adjusted too short, the internal bypass contact closes before the motor has reached its nominal speed. This can cause damage to the bypass contactor or the bypass relay.

10. Installation guidelines

10.1 Connection diagram

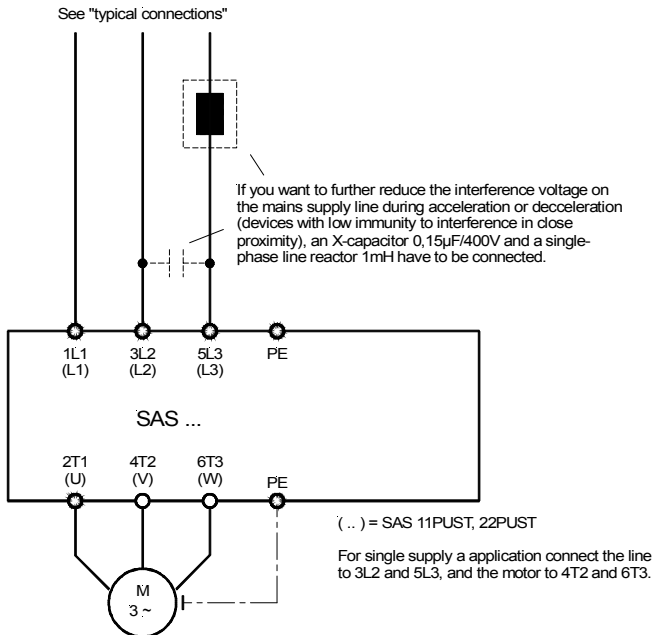

10.2 Typical connections

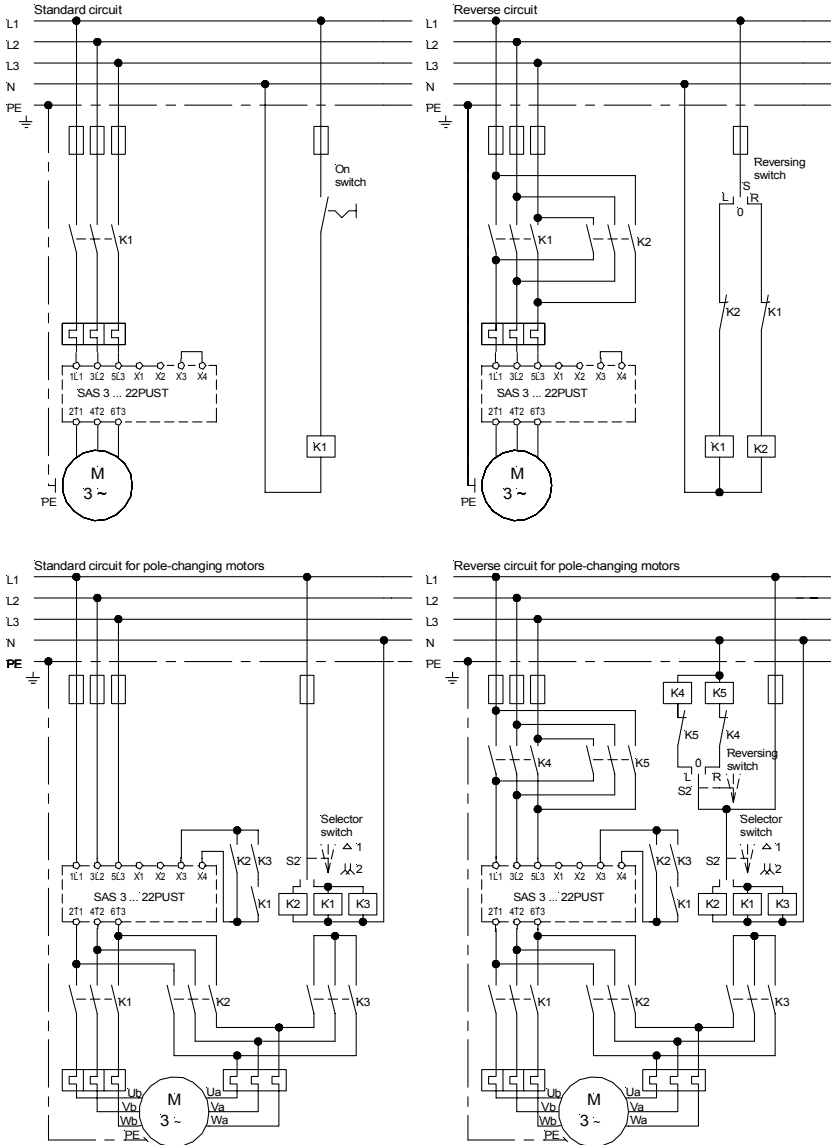

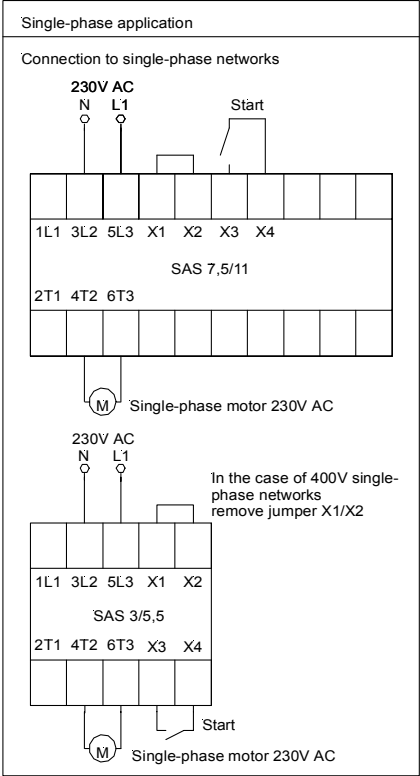

Notes:



www.peter-electronic.com

